

P-Type[®] Secondary Belt Cleaner

Installation, Operation and Maintenance Manual

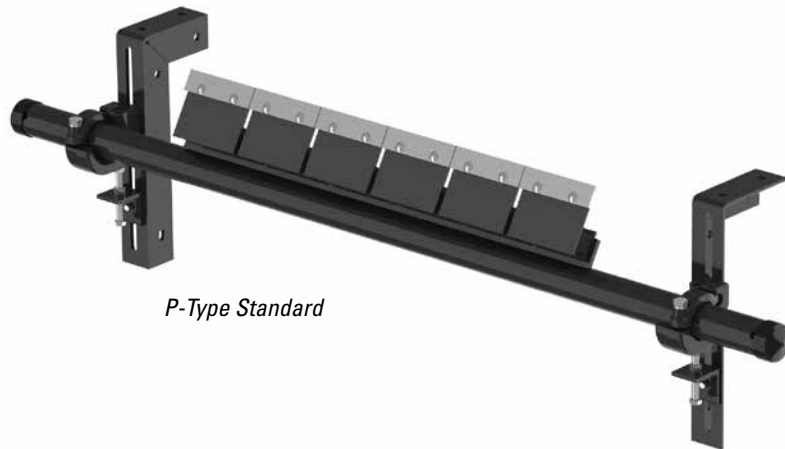

P-Type Standard

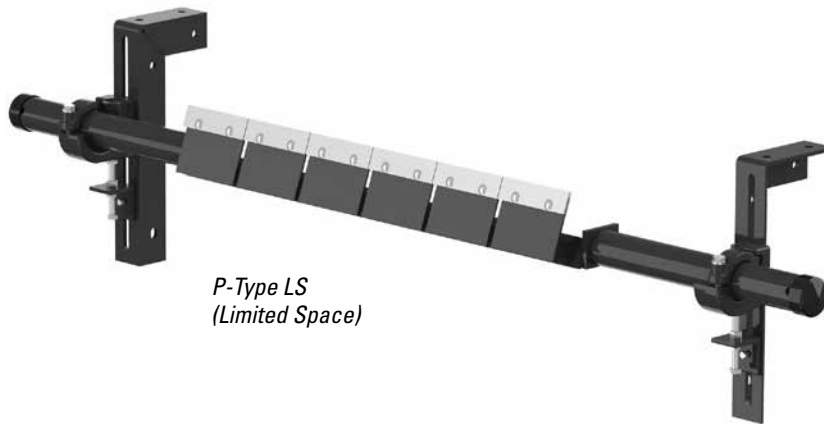

*P-Type LS
(Limited Space)*

P-Type® Secondary Belt Cleaner

Serial Number: _____
Purchase Date: _____
Purchased From: _____
Installation Date: _____

Serial number information can be found on the Serial Number Label included in the Information Packet found in the cleaner carton.

This information will be helpful for any future inquiries or questions about belt cleaner replacement parts, specifications or troubleshooting.

Table of Contents

Section 1 – Important Information	2
1.1 General Introduction	2
1.2 User Benefits	2
1.3 Service Option	2
Section 2 – Safety Considerations and Precautions	3
2.1 Stationary Conveyors.....	3
2.2 Operating Conveyors	3
Section 3 – Pre-Installation Checks and Options.....	4
3.1 Checklist	4
3.2 Optional Installation Accessories	4
Section 4 – P-Type® and P-Type LS Belt Cleaner Installation Instructions	5
Section 5 – Pre-Operation Checklist and Testing.....	9
5.1 Pre-Op Checklist	9
5.2 Test Run the Conveyor	9
Section 6 – Maintenance	10
6.1 New Installation Inspection.....	10
6.2 Routine Visual Inspection	10
6.3 Routine Physical Inspection.....	10
6.4 Blade Replacement Instructions.....	11
6.5 Maintenance Log.....	13
6.6 Cleaner Maintenance Checklist.....	14
Section 7 – Troubleshooting	15
Section 8 – Specs and CAD Drawings.....	16
8.1 Specs and Guidelines	16
8.2 CAD Drawing - P-Type with C-Tips	17
8.3 CAD Drawing - P-Type with V-Tips	18
8.4 CAD Drawing- P-Type LS with C-Tips.....	19
Section 9 – Replacement Parts	20
Section 10 – Other Flexco Conveyor Products.....	21

Section 1 – Important Information

1.1 General Introduction

We at Flexco are very pleased that you have selected a P-Type® Secondary Belt Cleaner for your conveyor system.

This manual will help you to understand the operation of this product and assist you in making it work up to its maximum efficiency over its lifetime of service.

It is essential for safe and efficient operation that the information and guidelines presented be properly understood and implemented. This manual will provide safety precautions, installation instructions, maintenance procedures and troubleshooting tips.

If, however, you have any questions or problems that are not covered, please visit our web site or contact our Customer Service Department:

Customer Service: 1-800-541-8028

Visit www.flexco.com for other Flexco locations and products.

Please read this manual thoroughly and pass it on to any others who will be directly responsible for installation, operation and maintenance of this cleaner. While we have tried to make the installation and service tasks as easy and simple as possible, **it does however require correct installation and regular inspections and adjustments to maintain top working condition.**

1.2 User Benefits

Correct installation and regular maintenance will provide the following benefits for your operation:

- Reduced conveyor downtime
- Reduced man-hour labor
- Lower maintenance budget costs
- Increased service life for the belt cleaner and other conveyor components

1.3 Service Option

The P-Type® Secondary Belt Cleaner is designed to be easily installed and serviced by your on-site personnel. However, if you would prefer complete turn-key factory service, please contact your local Flexco Field Representative.

Section 2 – Safety Considerations and Precautions

Before installing and operating the P-Type® Secondary Belt Cleaner, it is important to review and understand the following safety information.

There are set-up, maintenance and operational activities involving both **stationary** and **operating** conveyors. Each case has a safety protocol.

2.1 Stationary Conveyors

The following activities are performed on stationary conveyors:

- Installation
- Blade replacement
- Repairs
- Tension adjustments
- Cleaning

DANGER

It is imperative that OSHA/MSHA Lockout/Tagout (LOTO) regulations, 29 CFR 1910.147, be followed before undertaking the preceding activities. Failure to use LOTO exposes workers to uncontrolled behavior of the belt cleaner caused by movement of the conveyor belt. Severe injury or death can result.

Before working:

- Lockout/Tagout the conveyor power source
- Disengage any takeups
- Clear the conveyor belt or clamp securely in place

WARNING

Use Personal Protective Equipment (PPE):

- Safety eyewear
- Hardhats
- Safety footwear

Close quarters, springs and heavy components create a worksite that compromises a worker's eyes, feet and skull.

PPE must be worn to control the foreseeable hazards associated with conveyor belt cleaners. Serious injuries can be avoided.

2.2 Operating Conveyors

There are two routine tasks that must be performed while the conveyor is running:

- Inspection of the cleaning performance
- Dynamic troubleshooting

DANGER

Every belt cleaner is an in-running nip hazard. Never touch or prod an operating cleaner. Cleaner hazards cause instantaneous amputation and entrapment.

WARNING

Belt cleaners can become projectile hazards. Stay as far from the cleaner as practical and use safety eyewear and headgear. Missiles can inflict serious injury.

WARNING

Never adjust anything on an operating cleaner. Unforeseeable belt projections and tears can catch on cleaners and cause violent movements of the cleaner structure. Flailing hardware can cause serious injury or death.

Section 3 – Pre-installation Checks and Options

3.1 Checklist

- Check that the cleaner size is correct for the beltline width
- Check the belt cleaner carton and make sure all the parts are included
- Review the “Tools Needed” list on the top of the installation instructions
- Check the conveyor site:
 - Will the cleaner be installed on a chute
 - Is the install on an open head pulley requiring mounting structure

3.2 Optional Installation Accessories

Pole extenders are available for wide, non-standard conveyor structures.

76024

Pole Extender Kit

- Provides 30" (750mm) of extended pole length
- Includes 2 pole extenders

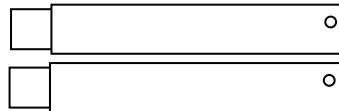

Optional Mounting Accessories

Description	Ordering Number	Item Code	Wt. Lbs.
Pole Extender Kit	MAPEK	76024	21.9
Lead time: 1 working day			

Section 4 – Installation Instructions

P-Type Secondary Belt Cleaner

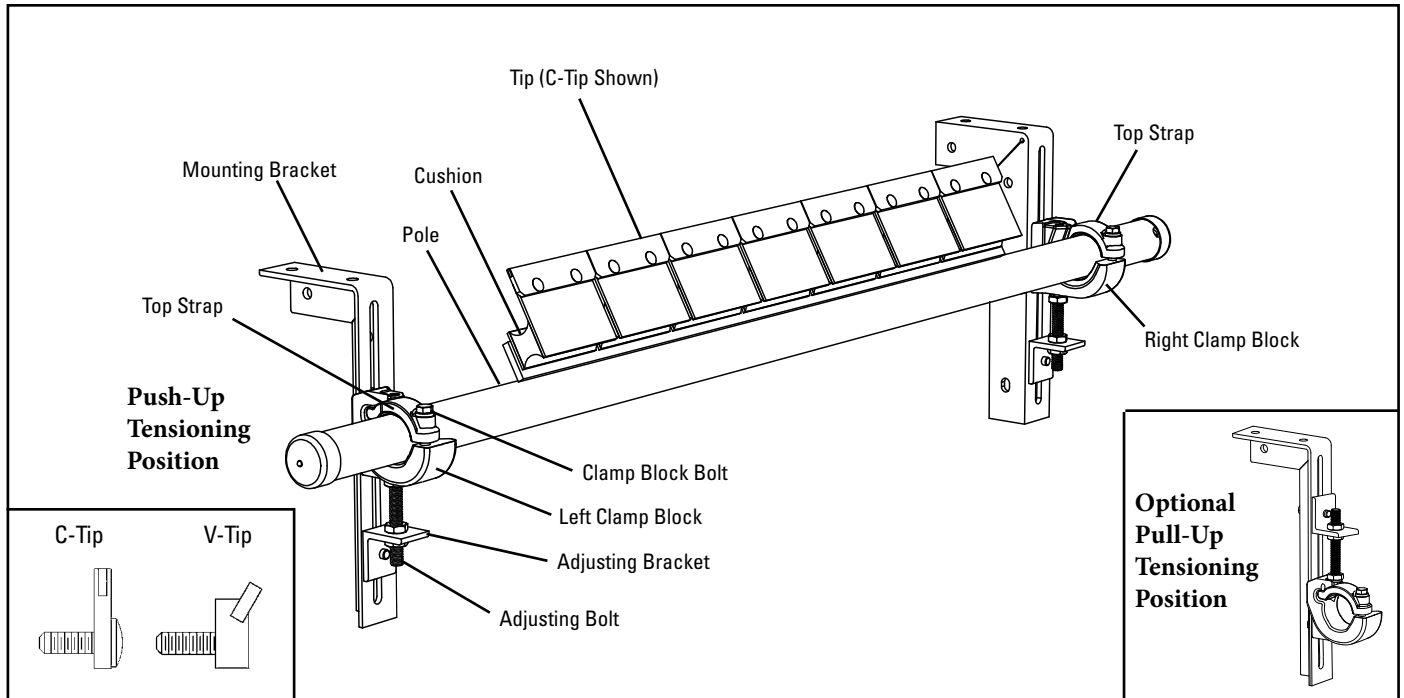

Physically lock out and tag the conveyor at the power source before you begin cleaner installation.

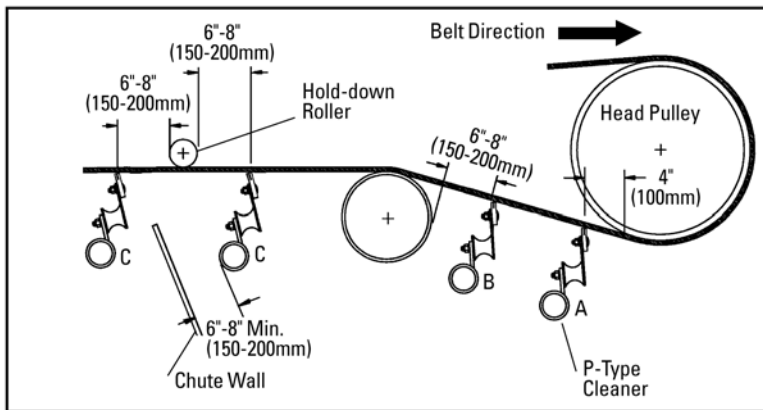

Tools Needed

- Tape Measure
- 3/4" (19mm) Wrench
- Ratchet With 3/4" (19mm) Socket
- (2) 6" C-Clamps (for Temporary Positioning of Mounting Brackets)
- Cutting Torch and/or Welder
- Marking Pen

Before You Begin:

- Double check the tip style needed for your application:
 C-Tip - for mechanically spliced and vulcanized belts.
 V-Tip - for vulcanized belts only.
- For chute mounting it may be necessary to cut an access hole to allow for installation and inspections. (See dimensions in STEP 2.)
- Follow all safety precautions when using a cutting torch.
- If welding, protect all fastener threads from weld spatter.
- For cleaner clearance requirements see chart. P-Type LS (available with C-Tip only) is designed for tighter space configurations.

Clearance Requirements for Installation

	Vertical	Horizontal
P-Type Cleaner	7" (175mm)	4" (100mm)
P-Type LS Cleaner	5-1/2" (138mm)	5" (125mm)

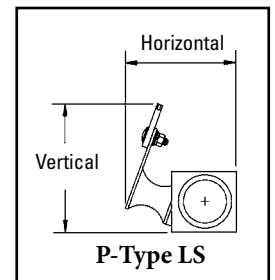
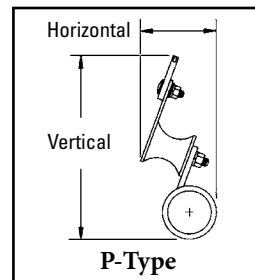

Section 4 – Installation Instructions (cont.)

P-Type Secondary Belt Cleaner

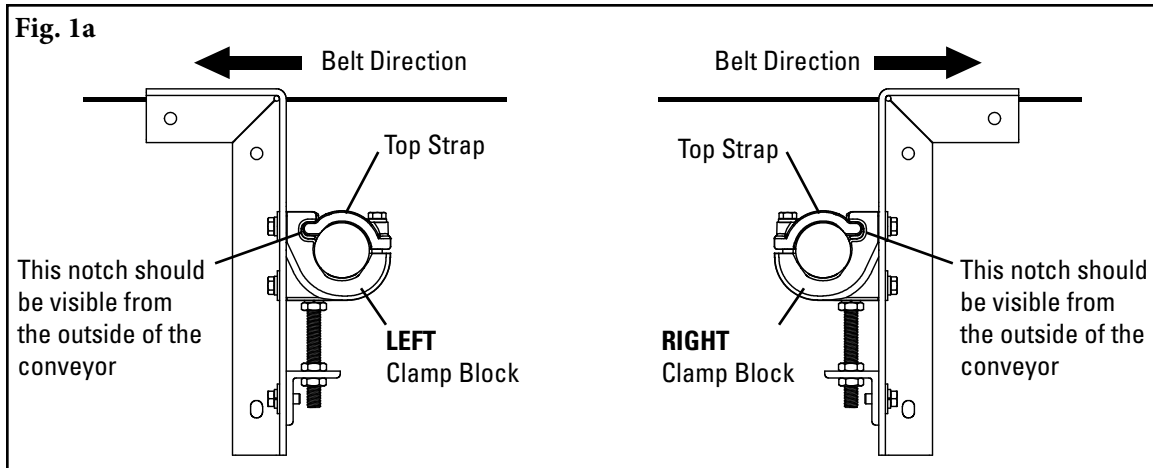

1. Install mounting brackets.

Determine the correct clamp block (left or right) and bracket needed for each side of the conveyor (Fig. 1a). The top strap should be offset away from the belt (you should be able to see the notch for the top strap from the outside of the conveyor).

For chute mounting: For a chute installation a belt location line must first be established. Draw a line on the chute replicating this location. If head pulley and snub pulley are close, it may be necessary to assume an approximate belt line between the two. In the determined location draw a line perpendicular to the belt line. Make a mark on this line 7" (175mm) (5-½"/138mm for PLS) below belt location line (Fig. 1b).

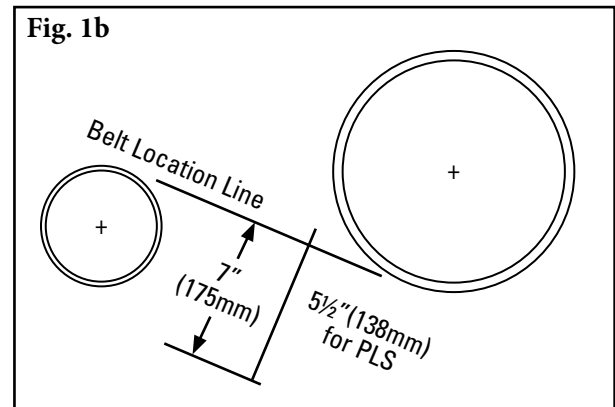

Locate a mounting bracket along the belt location line (Fig. 1b), allowing the centerline of the clamp block to align with the 7" (175mm) (5-½"/138mm for PLS) mark (Fig. 1c). To move the clamp blocks, if necessary, loosen the clamp block lock bolts and the adjusting bracket lock bolt and move the clamp block to a position where the center of the hole is 7" (175mm) (5-½"/138mm for PLS) below the bottom of the belt. Bolt or weld in place. Repeat this step on the opposite side. On one side an access hole may be required (Fig. 1d). **NOTE:** The mounting brackets must be aligned perpendicular to the belt.

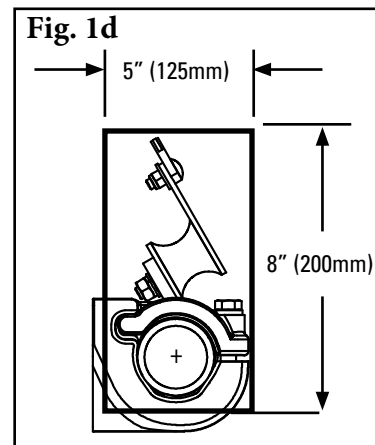
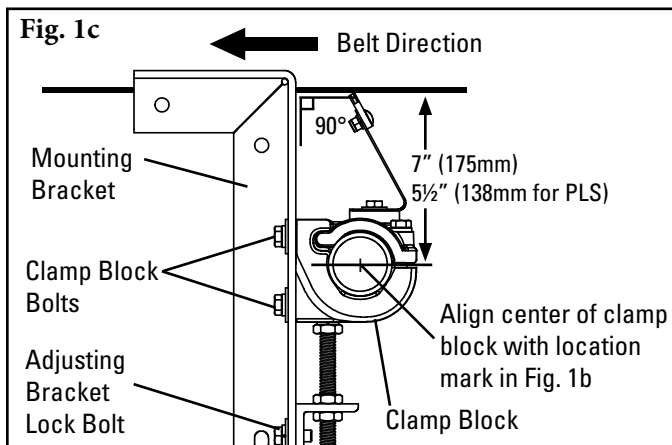

Section 4 – Installation Instructions (cont.)

P-Type Secondary Belt Cleaner

For structure mounting: In most applications the standard mounting brackets will have adequate room to fit on the structure with no cutting. Clamp the mounting bracket into position (use 6" clamps). Move the clamp block to align the center of the block with a point 7" (175mm) (5-½"/138mm for PLS) below the belt (Fig. 1e). To move the clamp blocks, if necessary, loosen the clamp block lock bolts and the adjusting bracket lock bolt and turn the adjusting bolt jam nuts. The bracket can now be bolted or welded in place. Locate and install bracket on the opposite side of belt in alignment with the first bracket. **NOTE:** The brackets must be aligned perpendicular to the belt.

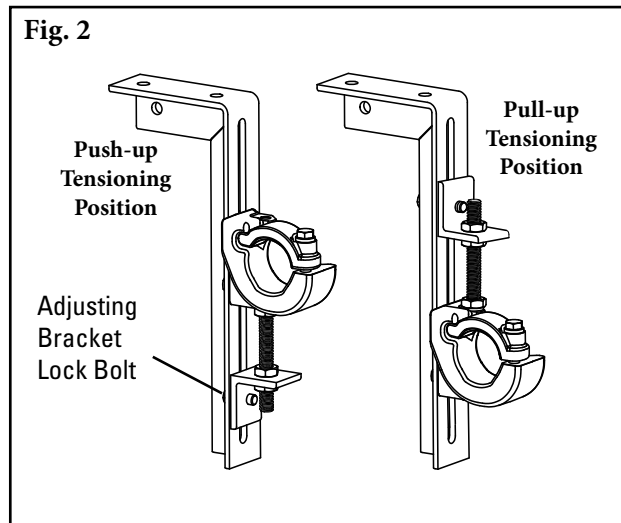
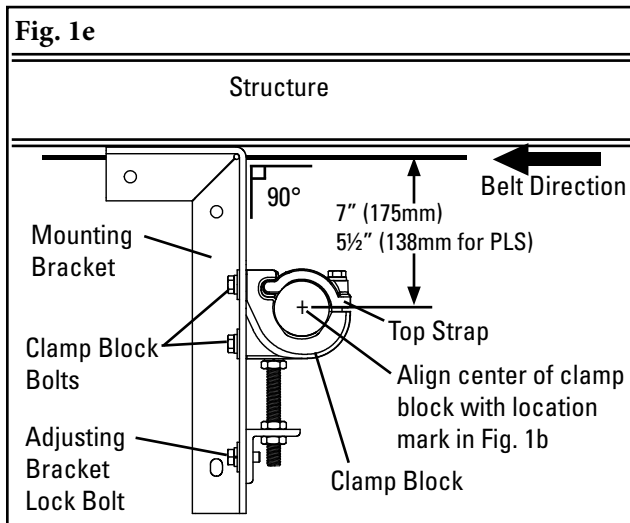

- 2. Choose the tensioner position.** The tensioner is shipped mounted in the push-up position. Depending upon the space constraints of the installation, the tensioner can be optionally mounted in a pull-up position. To do this, loosen the threaded rod lock nut, unscrew the threaded rod and remove adjusting bracket lock bolt. Then move the adjusting bracket and threaded rod to the top of the clamp blocks (Fig. 2) and tighten threaded rod lock nut.
- 3. Install the pole.** Remove the clamp block top strap on the access side of the conveyor, and on the opposite side loosen the clamp block bolt. Slide the pole across and into the loosened clamp block, place near end of pole in bottom section of clamp block (Fig. 3). Replace the top strap on the clamp block, center the blades on the belt and tighten both clamp block bolts finger tight.
- 4. Set the tip angle.** With angle gauge provided, rotate the tips to the preset angle (Fig. 3) and lock the pole in place by tightening the clamp block bolts equally. **NOTE:** Make sure there is NO tip-to-belt contact while making this alignment. If contact occurs, lower the pole by loosening the clamp block lock bolts and raising the top adjusting bolt jam nut (Fig. 4). When the tips are not touching the belt, repeat this step.

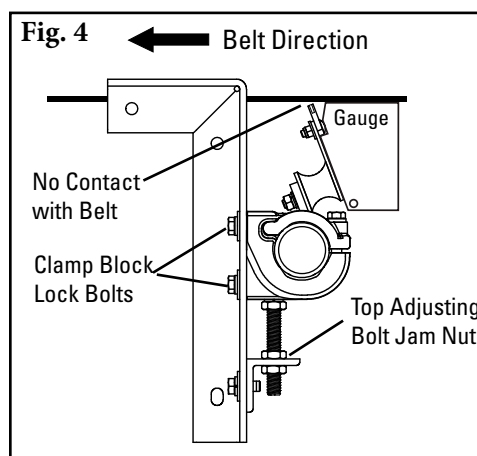
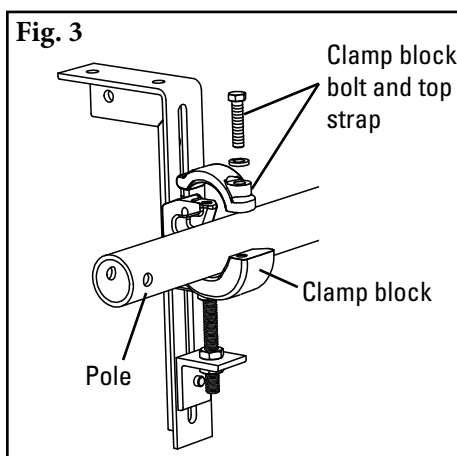

Section 4 – Installation Instructions (cont.)

P-Type Secondary Belt Cleaner

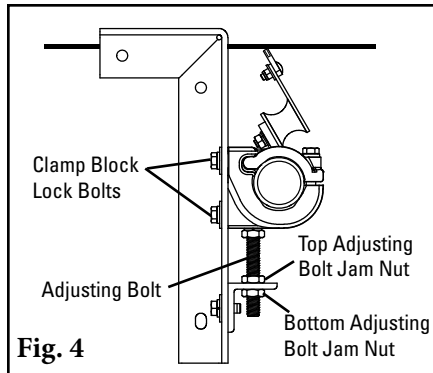

5. **Set the tip tension.** With all clamp block lock bolts slightly loosened, back down the bottom adjusting bolt jam nut 4-5 turns on both sides (Fig. 4). Turn the top adjusting bolt jam nuts down until light contact is made between the tips and belt across the entire width of the cleaner. Give an additional 1 turn to both top adjusting bolt jam nuts and tighten both bottom adjusting bolt jam nuts. Tighten all clamp block lock bolts. Double check that all bolts and nuts on the cleaner are tight.

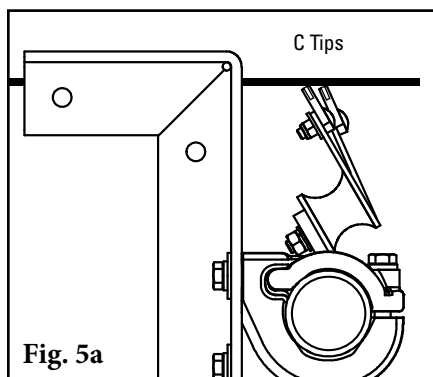

6. **Check the tip tension.** Pull back on the outside tip until the tip-to-belt contact is broken and release. If the cleaner is correctly tensioned the complete blade of the adjacent tip will be visible (Fig. 5a & 5b). If not, add (or reduce) tension by making 1/4 turn adjustments on the adjusting bolt as described in STEP 4 until the adjacent tip is visible.

Test run the cleaner and inspect its performance. If vibration occurs or more cleaning efficiency is desired, increase the tip tension by making a 1/4 turn adjustment on each adjusting bolt.

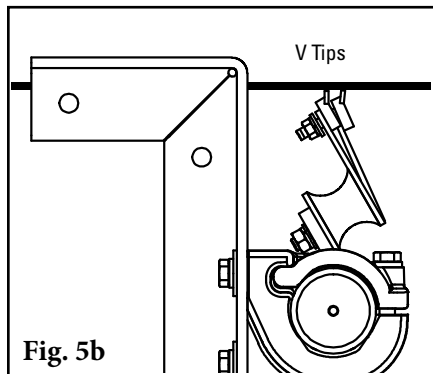

Section 5 – Pre-Operation Checklist and Testing

5.1 Pre-Op Checklist

- Recheck that all fasteners are tightened properly.
- Add pole caps.
- Apply all supplied labels to the cleaner.
- Check the blade location on the belt.
- Be sure that all installation materials and tools have been removed from the belt and the conveyor area.

5.2 Test Run the Conveyor

- Run the conveyor for at least 15 minutes and inspect the cleaning performance.
- Check adjusting brackets and tips for proper tensioning.
- Make adjustments as necessary.

NOTE: Observing the cleaner when it is running and performing properly will help to detect problems or when adjustments are needed later.

Section 6 – Maintenance

Flexco belt cleaners are designed to operate with minimum maintenance. However, to maintain superior performance some service is required. When the cleaner is installed a regular maintenance program should be set up. This program will ensure that the cleaner operates at optimal efficiency and problems can be identified and fixed before the cleaner stops working.

All safety procedures for inspection of equipment (stationary or operating) must be observed. The P-Type® Secondary Belt Cleaner operates at the discharge end of the conveyor and is in direct contact with the moving belt. Only visual observations can be made while the belt is running. Service tasks can be done only with the conveyor stopped and by observing the correct lockout/tagout procedures.

6.1 New Installation Inspection

After the new cleaner has run for a few days a visual inspection should be made to ensure the cleaner is performing properly. Make adjustments as needed.

6.2 Routine Visual Inspection (every 2-4 weeks)

A visual inspection of the cleaner and belt can determine:

- If adjusting brackets are set for optimal tensioning.
- If the belt looks clean or if there are areas that are dirty.
- If the blade is worn out and needs to be replaced.
- If there is damage to the blade or other cleaner components.
- If fugitive material is built up on the cleaner or in the transfer area.
- If there is cover damage to the belt.
- If there is vibration or bouncing of the cleaner on the belt.
- If a snub pulley is used, a check should be made for material buildup on the pulley.
- Significant signs of carryback

If any of the above conditions exist, a determination should be made on when the conveyor can be stopped for cleaner maintenance.

6.3 Routine Physical Inspection (every 6-8 weeks)

When the conveyor is not in operation and properly locked and tagged out a physical inspection of the cleaner to perform the following tasks:

- Clean material buildup off of the cleaner blade and pole.
- Closely inspect the blade for wear and any damage. Replace if needed.
- Ensure full blade to belt contact.
- Inspect the cleaner pole for damage.
- Inspect all fasteners for tightness and wear. Tighten or replace as needed.
- Replace any worn or damaged components.
- Check the tension of the cleaner blade to the belt. Adjust the tension if necessary using the steps on page 8.
- When maintenance tasks are completed, test run the conveyor to ensure the cleaner is performing properly.

Section 6 – Maintenance (cont.)

6.4 Blade Replacement Instructions (C-Tips or V-Tips)

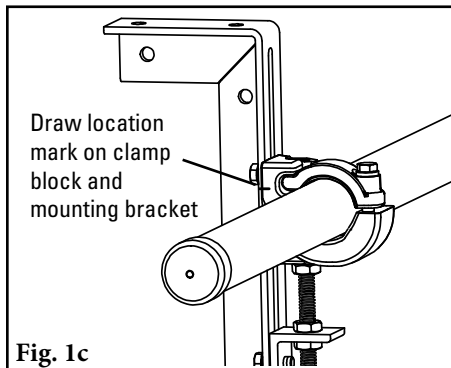
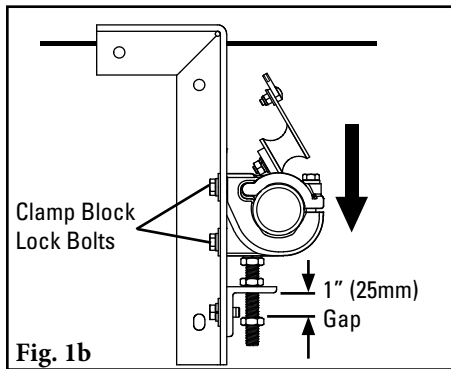
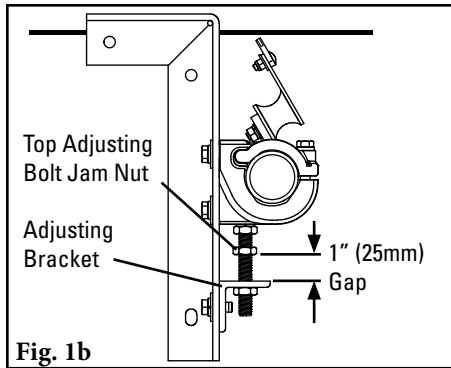

BEFORE YOU BEGIN:

Physically Lock Out And Tag The Conveyor At The Power Source.

1. Release the blade tension and remove worn blade tips.

- Loosen the top adjusting bolt jam nuts 1" (25mm) on the top of the adjusting brackets (Fig. 1a).
- Loosen the clamp block lock bolts on both sides and allow the pole to move down and rest on the raised top adjusting bolt jam nuts (Fig. 1b).
- Place location marks across the mounting bracket and the clamp block for quick positioning after blade replacement (Fig. 1c).
- Remove the clamp block lock bolts and adjusting bracket lock bolts on each side and remove the pole with the clamp blocks and adjusting brackets attached (Fig. 1d).
- Remove the nuts, flat washers and lock washers from the tips and remove worn tips (Fig. 1e).
- Insert new blade tips and install flat washers, lock washers and nuts finger tight. Buff the outside corners of the last tip on each side of the cleaner (Fig. 1f).

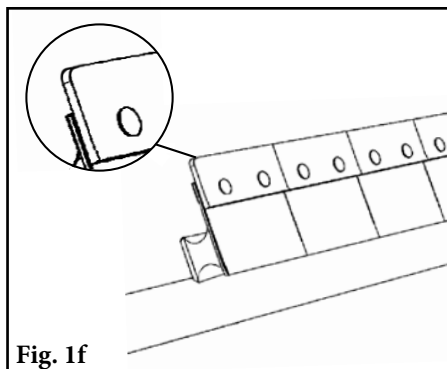
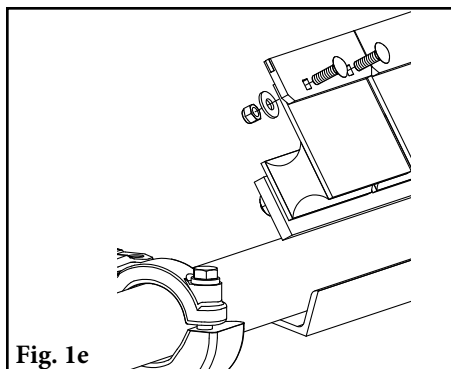
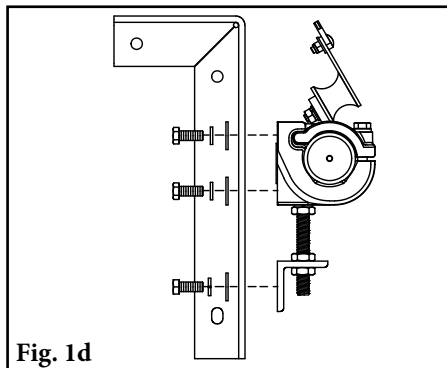

Section 6 – Maintenance (cont.)

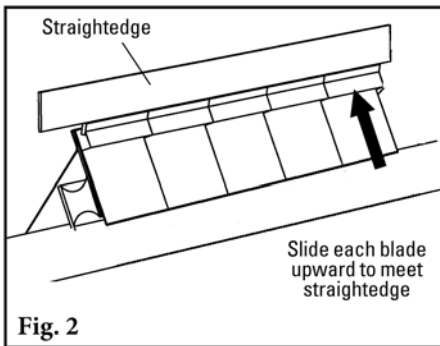

2. **Align the blade tips.** Push tips together so there is no more than a .010" to .015" gap between them. Position a straightedge along the top surface of new blade tips. Pull upward on each blade to align with the bottom of the straightedge and tighten the nuts (Fig. 2).

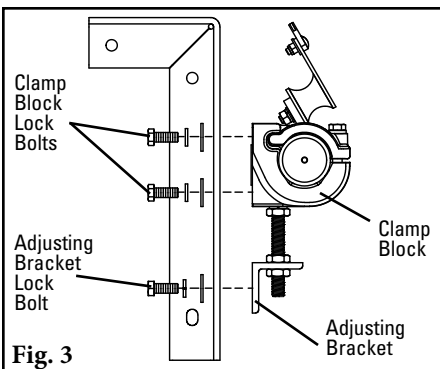

3. **Reinstall the pole.** Slide the pole back into position on the mounting brackets, aligning marks made on the bracket and the clamp block. Install the two adjusting bracket lock bolts and tighten. Install the four clamp block lock bolts finger tight (Fig. 3).

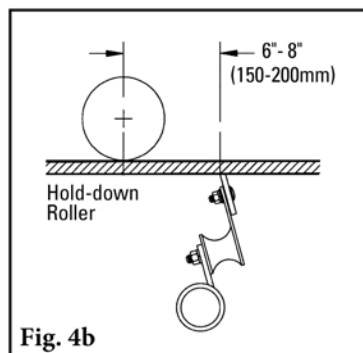
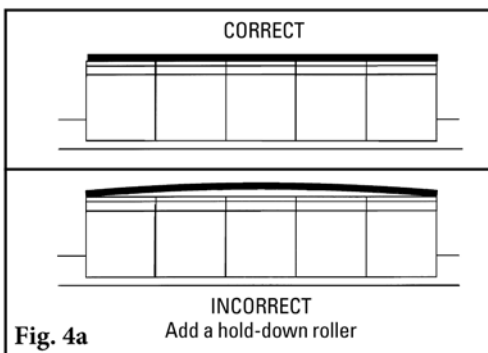

4. **Set the blade tension.** Turn the top adjusting bolt jam nuts down until light tip to belt contact is made across the entire width of the cleaner. Add an additional 1 turn on the top adjusting bolt jam nuts and lock the bottom adjusting bolt jam nuts. Tighten all clamp block lock bolts. **NOTE:** If the belt is cupped, do not overtension the blades to contact the belt. A hold-down roller should be installed to flatten the belt (Fig. 4a and 4b). (Try the Stabilizing Return Roller or Stabilizing Roller Bracket Kit.)

5. **Check the blade tip tension.** Pull back on the outer blade in the direction of belt travel until the blade breaks contact with the belt. Let go of the blade. With correct tension the full thickness of the adjacent blade tip should be visible in front of the outer blade (Fig. 5a and 5b). Also check the center blade in same manner. Add tension in 1/4-turn increments on the top adjusting bolt jam nuts until view of full thickness of the adjacent blade tip is achieved.

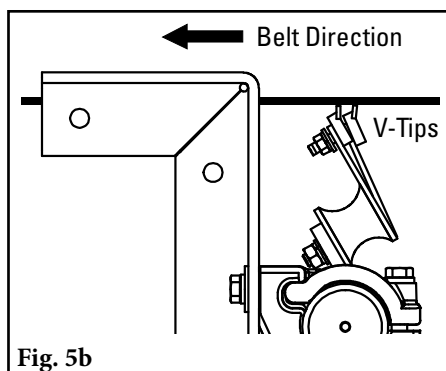
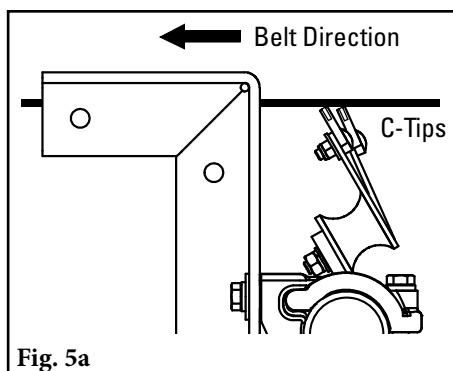

6. **Test run cleaner and inspect operation.** If vibration occurs, increase tip tension by making 1/4-turn adjustments.

Section 6 – Maintenance (cont.)

6.5 Maintenance Log

Conveyor Name/No. _____

Date: _____ Work done by: _____ Service Quote # _____

Activity: _____

Date: _____ Work done by: _____ Service Quote # _____

Activity: _____

Date: _____ Work done by: _____ Service Quote # _____

Activity: _____

Date: _____ Work done by: _____ Service Quote # _____

Activity: _____

Date: _____ Work done by: _____ Service Quote # _____

Activity: _____

Date: _____ Work done by: _____ Service Quote # _____

Activity: _____

Date: _____ Work done by: _____ Service Quote # _____

Activity: _____



Section 6 – Maintenance (cont.)

6.6 Cleaner Maintenance Checklist

Site: _____ Inspected by: _____ Date: _____

Belt Cleaner: _____ Serial Number: _____

Beltline Information:

Beltline Number: _____ Belt Condition: _____

Belt Width: 18" (450mm) 24" (600mm) 30" (750mm) 36" (900mm) 42" (1050mm) 48" (1200mm) 54" (1350mm) 60" (1500mm) 72" (1800mm)

Head Pulley Diameter (Belt & Lagging): _____ Belt Speed: _____ fpm Belt Thickness: _____

Belt Splice _____ Condition of Splice _____ Number of splices _____ Skived Unskived

Material conveyed _____

Days per week run _____ Hours per day run _____

Blade Life:

Date blade installed: _____ Date blade inspected: _____ Estimated blade life: _____

Is blade making complete contact with belt? Yes No

Blade wear: LEFT _____ MIDDLE _____ RIGHT _____

Blade condition: Good Grooved Smiled Not contacting belt Damaged

Measurement of spring: Required _____ Currently _____

Was Cleaner Adjusted: Yes No

Pole Condition: Good Bent Worn

Lagging: Slide lag Ceramic Rubber Other None

Condition of lagging: Good Bad Other _____

Cleaner's Overall Performance: (Rate the following 1 - 5, 1 = very poor - 5 = very good)

Appearance: Comments: _____

Location: Comments: _____

Maintenance: Comments: _____

Performance: Comments: _____

Other Comments: _____

Section 7 – Troubleshooting

Problem	Possible Cause	Possible Solutions
Vibration	Cleaner secure bolts not set	Ensure all locking nuts are tight (Loctite)
	Cleaner not set up correctly	Ensure cleaner set up properly (check tip angle with gauge)
	Belt tension too high	Ensure cleaner can conform to belt, or replace with alternate Flexco secondary cleaner
	Belt flap	Introduce hold-down roller to flatten belt
	Cleaner over-tensioned	Ensure cleaner is correctly tensioned
	Cleaner under-tensioned	Ensure cleaner is correctly tensioned
Material buildup on cleaner	Cleaner not set up correctly	Ensure cleaner set up properly (check tip angle with gauge)
	Buildup on chute	Ensure cleaner is not located too close to back of chute, allowing buildup
	Cleaner being overburdened	Introduce Flexco precleaner
	Excessive sticky material	Frequently clean unit of buildup
Damaged belt cover	Cleaner over-tensioned	Ensure cleaner is correctly tensioned
	Cleaner blade damage	Check blade for wear, damage and chips, replace where necessary
	Attack angle not correct	Ensure cleaner set up properly (check tip angle with gauge)
	Material buildup in chute	Frequently clean unit of buildup
Cleaner not conforming to belt	Cleaner not set up correctly	Ensure cleaner set up properly (check tip angle with gauge)
	Belt tension too high	Ensure cleaner can conform to belt, introduce hold-down roller, or replace with alternate Flexco secondary cleaner
	Belt flap	Introduce hold-down roller to flatten belt
	Cleaner cannot conform	Ensure cleaner can conform to belt, introduce hold-down roller, or replace with alternate Flexco secondary cleaner
Material passing cleaner	Cleaner not set up correctly	Ensure cleaner set up properly (check tip angle with gauge)
	Cleaner tension too low	Ensure cleaner is correctly tensioned
	Cleaner blade worn/damaged	Check blade for wear, damage and chips, replace where necessary
	Cleaner being overburdened	Introduce Flexco precleaner
	Belt flap	Introduce hold-down roller to flatten belt
	Belt worn or grooved	Introduce water spray pole
	Cleaner cannot conform	Ensure cleaner can conform to belt, introduce hold-down roller, or replace with alternate Flexco secondary cleaner
Damage to mechanical fastener	Incorrect cleaner blade selection	Change blade type to accommodate fastener style (C-Tip or V-Tip)
	Belt not skived correctly	Spot and redo splice correctly, lowering the profile flush or below belt surface
	Blade angle incorrect	Reset with gauge
Missing material in belt center only	Cupped Belt	Install hold-down roller and reset blade angle with gauge
	Cleaner blade worn/damaged	Check blade for wear, damage and chips, replace where necessary
Missing material on outer edges only	Cupped Belt	Install hold-down roller and reset blade angle with gauge
	Cleaner blade worn/damaged	Check blade for wear, damage and chips, replace where necessary

Section 8 – Specifications and CAD Drawings

8.1 Specifications and Guidelines

Pole Length Specifications

CLEANER SIZE		POLE LENGTH		MAXIMUM CONVEYOR SPAN	
in.	mm	in.	mm	in.	mm
18	450	48	1200	43	1075
24	600	54	1350	49	1225
30	750	60	1500	55	1375
36	900	66	1650	61	1525
42	1050	72	1800	67	1675
48	1200	78	1950	73	1825
54	1350	88	2200	83	2075
60	1500	94	2350	89	2225
72	1800	106	2650	101	2525

Pole Diameter - 2-3/8" (60mm)

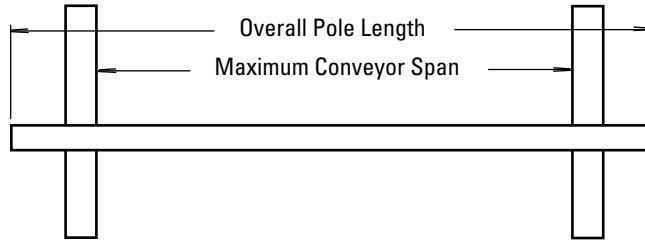

Clearance Guidelines for Installation

Cleaner Type	Belt Width/ Cleaner Size		Horizontal Clearance Required		Vertical Clearance Required	
	in.	mm	in.	mm	in.	mm
P-Type	18 - 72	450 - 1800	4	100	8	200
P-Type LS	18 - 54	450 - 1350	5	125	5 1/2	138

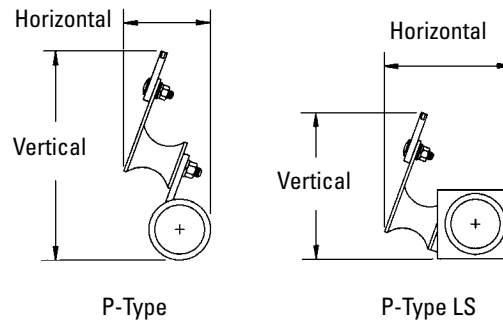

P-Type Cushion Specifications

Cushion	Durometer	Temperature Range
Standard	55A	-30° to 180°F -35° to 82° C
Neoprene	55A	-4° to 230°F -20° to 110°C

Specifications:

- Maximum Belt Speed.....1000 FPM (5M/sec)
- Temperature Rating.....-30°F to 180°F (-35°C to 82°C)
- Usable Blade Wear Length.....3/8" (9mm)
- Blade MaterialsC-Tip: Impact Resistant Tungsten Carbide
(works with mechanical fasteners)
V-Tip: Long Life Tungsten Carbide
(works on vulcanized belts only)
- Available for Belt Widths.....P-Type: 18" to 72" (450 to 1800mm)
P-Type LS: 18" to 54" (450 to 1350mm)
Other sizes available upon request.
- CEMA Cleaner Rating.....Class 4

Section 8 – Specifications and CAD Drawings (cont.)

8.2 CAD Drawing – P-Type with C-Tips

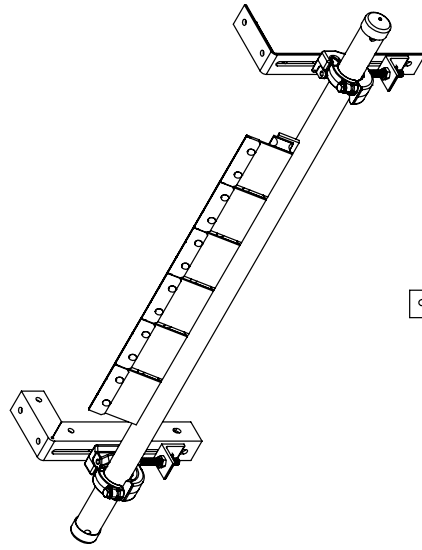

SPECIFICATIONS			P-TYPE CLEANER		
BELT WIDTH 'A' (in)	BELT WIDTH 'A' (mm)	POLE LENGTH 'B' (in)	# OF BLADES	ORDER NUMBER	ITEM CODE
18	450	48	3	PC18	74566
24	600	54	4	PC24	74567
30	750	60	5	PC30	74568
36	900	66	6	PC36	74569
42	1050	72	7	PC42	74570
48	1200	78	8	PC48	74571
54	1350	88	9	PC54	74572
60	1500	94	10	PC60	74573
72	1800	106	12	PC72	74574

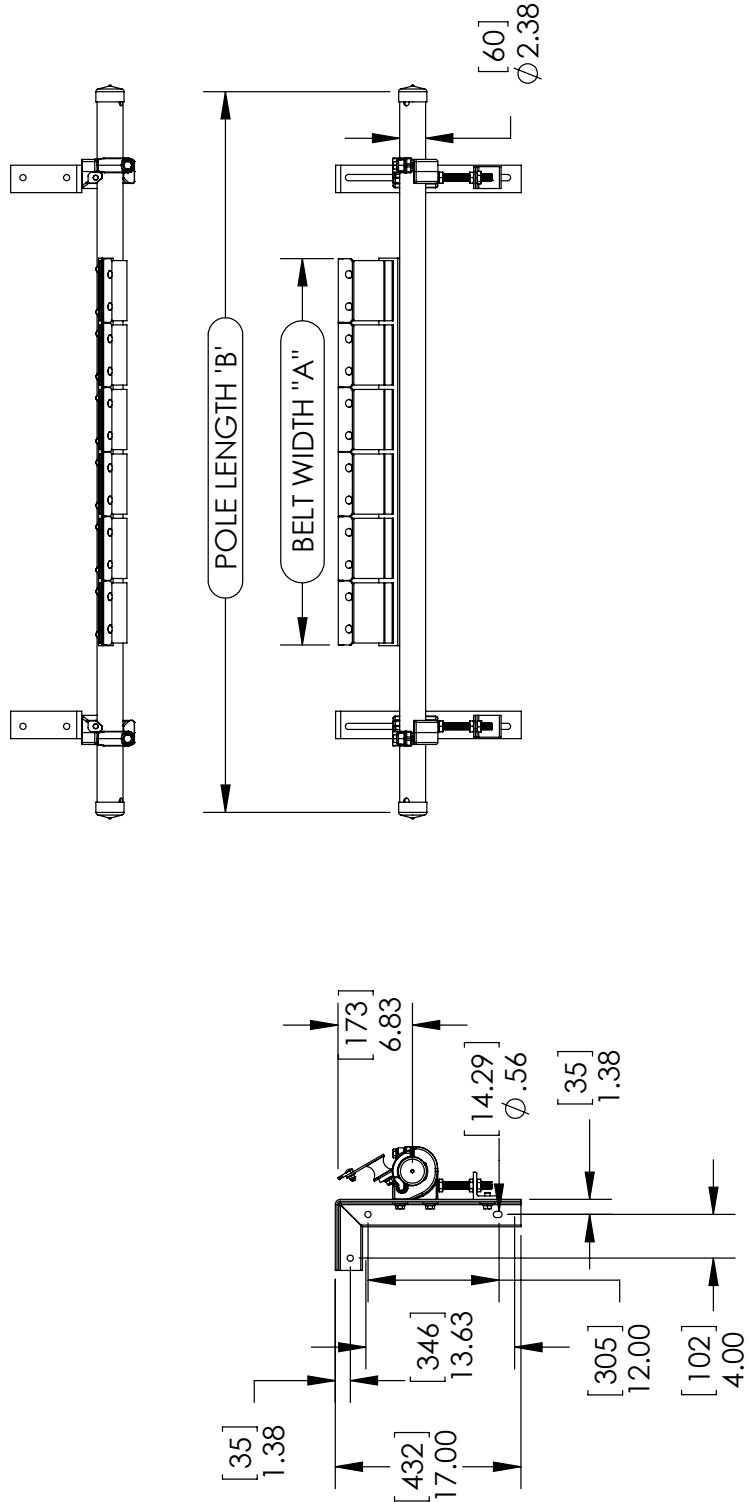

Section 8 – Specifications and CAD Drawings (cont.)

8.3 CAD Drawing – P-Type with V-Tips

SPECIFICATIONS		P-TYPE SECONDARY V-TIPS	
BELT WIDTH 'A' (in)	POLE LENGTH 'B' (in)	ORDER NUMBER	ITEM CODE
18	48	PV-18	78453
24	54	PV-24	78415
30	60	PV-30	78417
36	66	PV-36	78419
42	72	PV-42	78421
48	78	PV-48	78423
54	84	PV-54	78454
60	90	PV-60	78455
72	106	PV72	73438

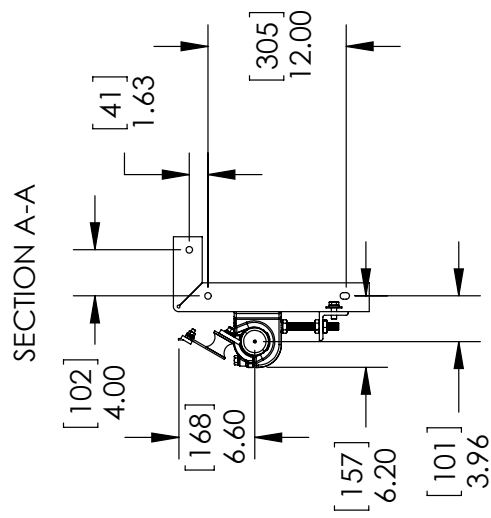
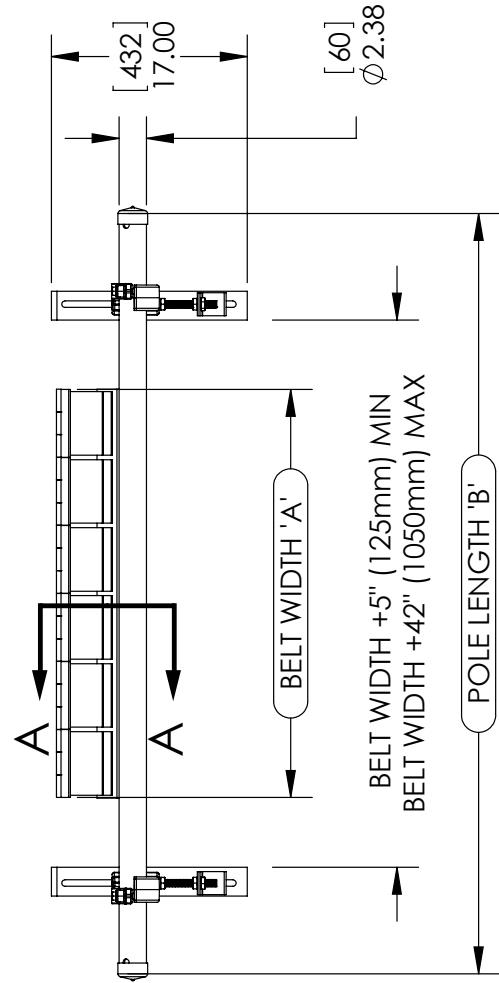
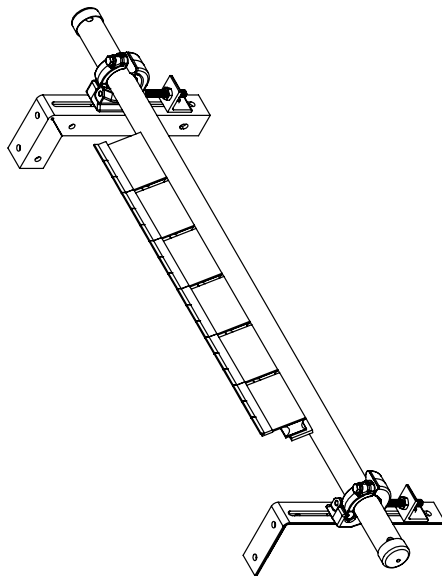

Section 8 – Specifications and CAD Drawings (cont.)

8.4 CAD Drawing – P-Type LS with C-Tips

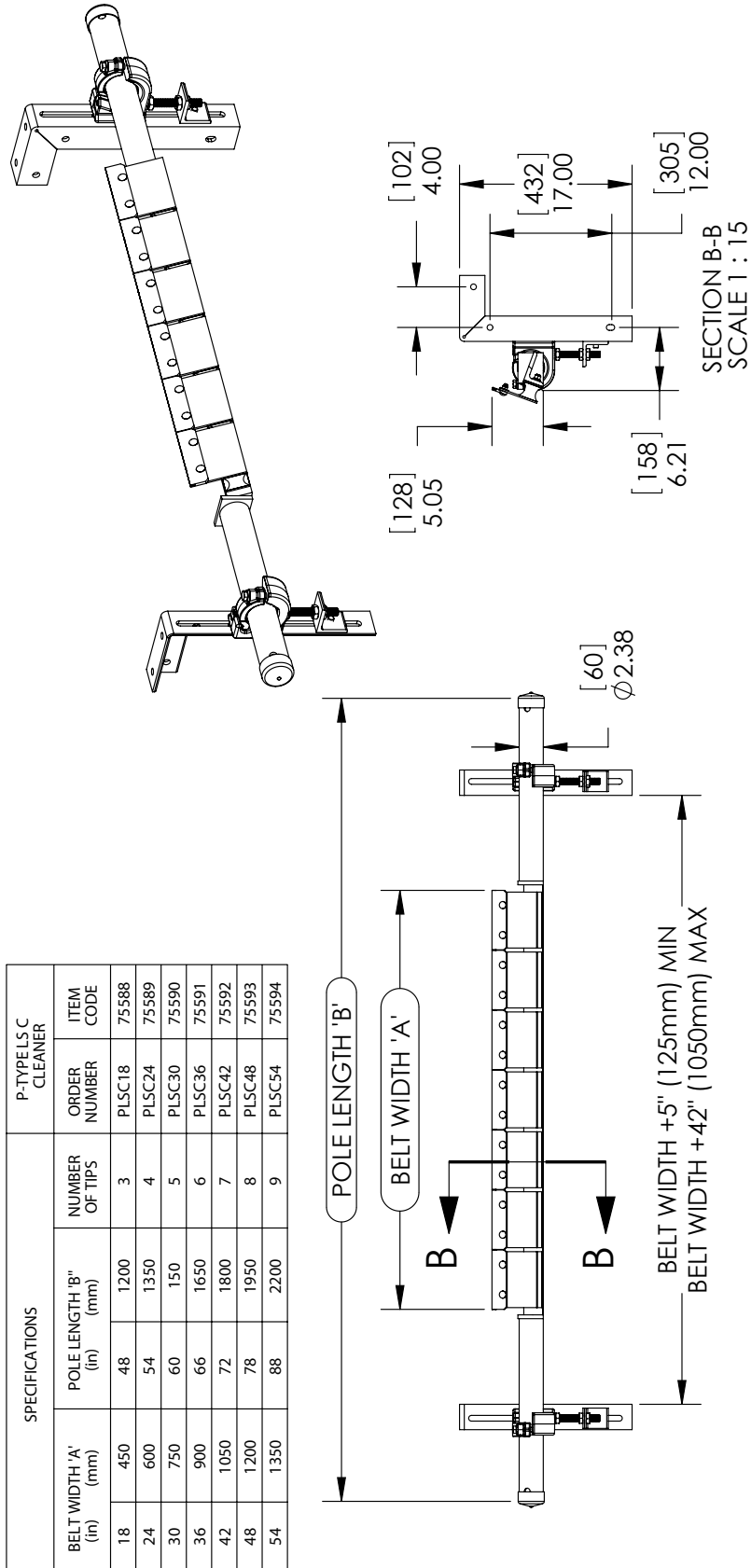

Section 9 – Replacement Parts List

9.1 Replacement Parts List- P-Type Secondary Belt Cleaner

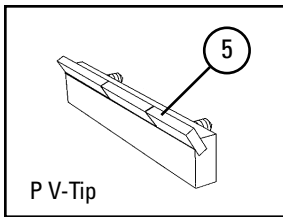
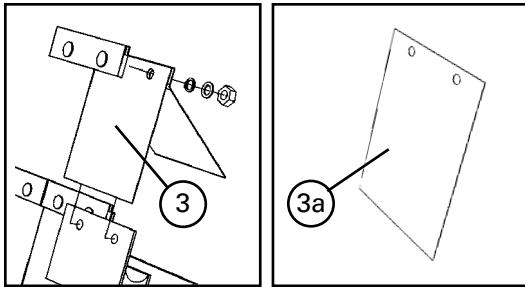
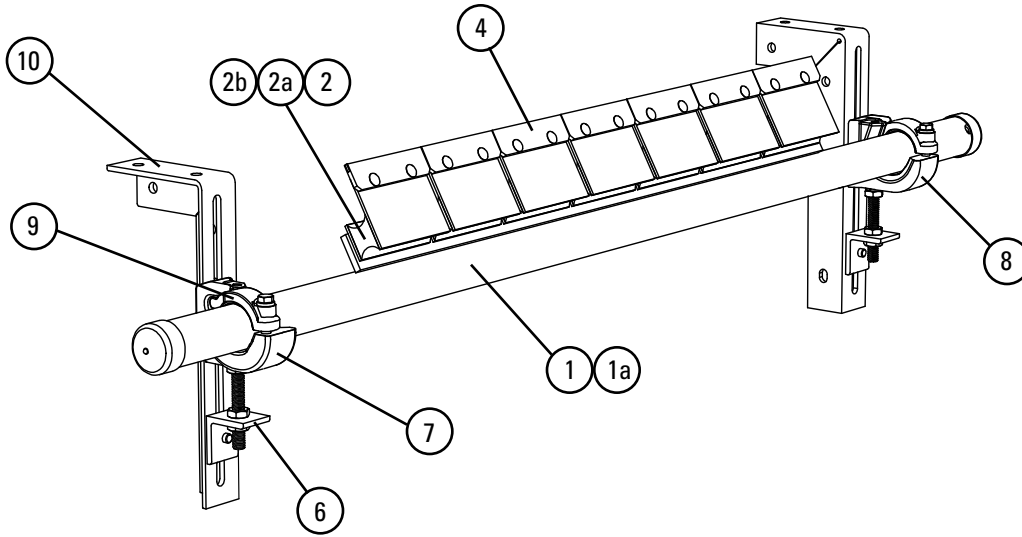

Replacement Parts

REF	DESCRIPTION	ORDERING NUMBER	ITEM CODE	WT. LBS.
1	18" (450mm) Pole	PP-18	78414	22.5
	24" (600mm) Pole	PP-24	78416	26.0
	30" (750mm) Pole	PP-30	78418	32.3
	36" (900mm) Pole	PP-36	78420	33.0
	42" (1050mm) Pole	PP-42	78422	43.0
	48" (1200mm) Pole	PP-48	78424	47.5
	54" (1350mm) Pole	PP-54	78425	55.0
	60" (1500mm) Pole	PP-60	78451	58.0
1a	72" (1800mm) Pole	PP72	73017	64.0
	18" (450mm) LS Pole	PLSP18	75595	32.3
	24" (600mm) LS Pole	PLSP24	75596	36.0
	30" (750mm) LS Pole	PLSP30	75597	38.7
	36" (900mm) LS Pole	PLSP36	75598	42.4
	42" (1050mm) LS Pole	PLSP42	75599	46.1
	48" (1200mm) LS Pole	PLSP48	75600	49.8
54" (1350mm) LS Pole	PLSP54	75601	53.5	
2	P2 C-Tip Cushion*	PHA	73626	2.0
2a	P Cushion SS Neoprene* (oil resistant)	PSSC	77045	3.5
2b	P Cushion Neoprene* (oil resistant)	PNC	74984	3.5
3	P Polyshield	PPS6	78450	0.5
3a	P SS Shield	PSSS	78434	0.5
4	C-Tip* Kit (1 ea.)	ICT6	74535	0.7
5	P V-Tip* (for vulcanized belts only)	PSA150	73156	1.0
6	Adjusting Bracket Kit* (1 ea.)	PAB	75513	1.5
7	Pole Clamp Kit Left* (1 ea.) (incl. 1 item 9)	CCKL	79224	6.8
8	Pole Clamp Kit Right* (1 ea.) (incl. 1 item 9)	CCKR	79228	6.8
9	Pole Clamp Top Strap (1 ea.) For use on left or right Pole Clamp Kit	CCKTS	79232	1.1
10	Mounting Bracket Kit (1 Right and 1 Left)	EZS2MBK	75666	13.0
	Cradle Clamp Mounting Kit* for sizes 18"-54" (450-1350mm) (incl. 2 items 6 and 1 ea. item 7, 8 & 10)	CCMK	78919	33.0

*Hardware included
Lead time: 1 working day

Tips Required per Cleaner Size

in.	18	24	30	36	42	48	54	60	72
mm	450	600	750	900	1050	1200	1350	1500	1800
C-Tips or V-Tips Required	3	4	5	6	7	8	9	10	12

Section 10 – Other Flexco Conveyor Products

Flexco provides many conveyor products that help your conveyors to run more efficiently and safely. These components solve typical conveyor problems and improve productivity. Here is a quick overview on just a few of them:

Rockline® EZP1 Precleaner



- Patented ConShear™ blade renews its cleaning edge as it wears
- Visual Tension Check™ for optimal blade tensioning and simple retensioning
- Quick and easy one-pin blade replacement Material Path Option™ for optimal cleaning and reduced maintenance

DRX Impact Beds



- Exclusive Velocity Reduction Technology™ to better protect the belt
- Slide-Out Service™ gives direct access to all impact bars for change-out
- Impact bar supports for longer bar life
- 4 models to custom fit to the application

Rockline® EZS2 Secondary Cleaner

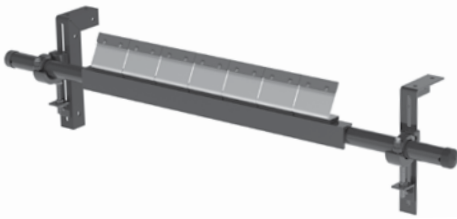

- Long-wearing tungsten carbide blades for superior cleaning efficiency
- Patented FormFlex™ cushions independently tension each blade to the belt for consistent, constant cleaning power
- Easy to install, simple to service
- Works with Flexco mechanical belt splices

PT Max™ Belt Trainer



- Patented “pivot & tilt” design for superior training action
- Dual sensor rollers on each side to minimize belt damage
- Pivot point guaranteed not to freeze up
- Available for topside and return side belts

Flexco Specialty Belt Cleaners



- “Limited space” cleaners for tight conveyor applications
- High Temp cleaners for severe, high heat applications
- A rubber fingered cleaner for chevron and raised rib belts
- Multiple cleaner styles in stainless steel for corrosive applications

Belt Plows



- A belt cleaner for the tail pulley
- Exclusive blade design quickly spirals debris off the belt
- Economical and easy to service
- Available in vee or diagonal models

The Flexco Vision

To become the leader in maximising
belt conveyor productivity for our customers worldwide
through superior service and innovation.

Flexco Europe GmbH • Leidringer Strasse 40-42 • D-72348 Rosenfeld • Deutschland
Tel: +49-7428-9406-0 • Fax: +49-7428-9406-260 • E-mail: europa@flexco.com

Besuchen Sie www.flexco.com, um andere Standorte und Produkte von Flexco kennenzulernen.

©2015 Flexible Steel Lacing Company, 11/15. For reorder: X2404

